

TPK30KPXX TVS Rectifier

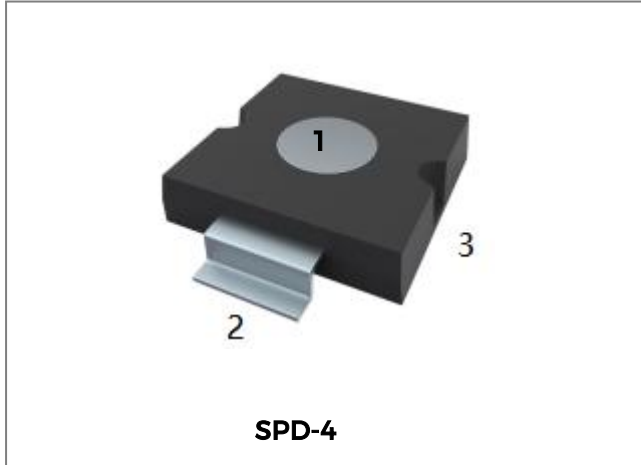

Features

- Low profile surface mount
- Fast response
- Suppresses transients up to 30kW @ 10/1000 μ s and 200kW @ 8/20 μ s
- This is a Pb - Free Device
- Open top for heat dissipation and different connection options
- Base plate: Pure Sn plated; Terminals: Pure Sn plated
- Base plate is cathode, Terminal is anode
- "A" Suffix designates unidirectional
- "CA" Suffix designates bidirectional
- All SMC parts are traceable to the wafer lot
- All part are 100% tested: electrical, 1x surge test, visual inspection
- Additional testing can be offered upon request

Applications

- Protection from switching transients and induced RF

Maximum Ratings and Thermal Characteristics @ $T_A = 25^\circ\text{C}$ unless otherwise specified

Characteristic	Symbol	Value	Unit
Junction and Storage Temperature Range	T_J, T_{STG}	-55 to +150	$^\circ\text{C}$
Thermal Resistance Junction to Ambient (Note 1)	$R_{\theta JA}$	50	$^\circ\text{C/W}$
Thermal Resistance Junction to Case	$R_{\theta JC}$	1.0	$^\circ\text{C/W}$
Peak Pulse Power@10/1000 μ s(Note 2)	P_{PP}	30,000	W
$T_{P\text{clamping}}$ (0 volts to $V_{(BR)}$ min) Unidirectional		<100	ps
Forward Clamping Voltage @ 500 Amps (Note 3)	V_{FS}	4.0	V
Forward Surge Current (Note 3)	I_{FSM}	1500	A
Solder Temperature @ 10 s	T_{SP}	260	$^\circ\text{C}$
Steady-State Power dissipation @ $T_A = 25^\circ\text{C}$ @ $T_C = 100^\circ\text{C}$	P_D	2.5 (Note 1) 50 (Note 4)	W
Approximate Weight	wt	2.35	g

Note: 1. When mounted on FR4 board with recommended mounting pad(see pad layout).

2. With impulse repetition rate (duty factor) of 0.05% or less.
3. At 8.3ms Single half sine-wave (unidirectional devices only)
4. Case temperature controlled heat sink as specified.
5. Derating when P_{PP} also applying steady-state power.

Electrical Characteristics @T_A=25°C unless otherwise specified

Part Number (Unidirectional)	Part Number (Bidirectional)	Stand-off Voltage V _{WM} (Note 1) (V)	Breakdown Voltage V _{BR} @ I _{BR} (mA) (V)		Clamping Voltage V _c (10*1000) @ I _{PP} (V) Max	Stand By Current I _R @ V _{WM} (μA) Max	Stand By Current I _R @ V _{WM} T _J =150°C (μA) Max	Peak Pulse Current I _{PP} Max (A)	Temperatur e Coefficient Of V _{BR} mV/°C Max
TPK30KP20A	TPK30KP20CA	20	22.2-24.5	5	34.0	45	800	882	18
TPK30KP22	TPK30KP22C	22	24.4-29.8	5	40.2	10	200	747	22
TPK30KP22A	TPK30KP22CA	22	24.4-26.9	5	36.4	10	200	822	20
TPK30KP24	TPK30KP24C	24	26.7-32.6	5	44.0	10	200	681	24
TPK30KP24A	TPK30KP24CA	24	26.7-29.5	5	39.8	10	200	753	22
TPK30KP26	TPK30KP26C	26	28.9-35.3	5	47.6	10	200	630	27
TPK30KP26A	TPK30KP26CA	26	28.9-31.9	5	43.0	10	200	696	24
TPK30KP28	TPK30KP28C	28	31.1-38.0	5	51.6	10	200	582	29
TPK30KP28A	TPK30KP28CA	28	31.1-34.4	5	46.4	10	200	645	26
TPK30KP30	TPK 30KP30C	30	33.3-40.7	5	53.8	10	200	564	36
TPK30KP30A	TPK 30KP30CA	30	33.3-36.8	5	48.8	10	200	618	30
TPK30KP33	TPK30KP33C	33	36.7-44.9	5	59.0	10	200	510	37
TPK30KP33A	TPK30KP33CA	33	36.7-40.6	5	53.3	10	200	564	35
TPK30KP36	TPK30KP36C	36	40.0-48.9	5	63.4	10	200	468	40
TPK30KP36A	TPK30KP36CA	36	40.0-44.2	5	58.1	10	200	516	38
TPK30KP40	TPK30KP40C	40	44.4-54.3	5	71.4	10	200	420	48
TPK30KP40A	TPK30KP40CA	40	44.4-49.1	5	64.5	10	200	468	44
TPK30KP43	TPK30KP43C	43	47.8-58.4	5	76.7	10	200	390	53
TPK30KP43A	TPK30KP43CA	43	47.8-52.8	5	69.4	10	200	432	50
TPK30KP45	TPK30KP45C	45	50.0-61.1	5	80.3	10	200	372	54
TPK30KP45A	TPK30KP45CA	45	50.0-55.3	5	72.7	10	200	414	51
TPK30KP48	TPK30KP48C	48	53.3-65.1	5	85.5	10	200	348	60
TPK30KP48A	TPK30KP48CA	48	53.3-58.9	5	77.4	10	200	390	54
TPK30KP51	TPK30KP51C	51	56.7-69.3	5	91.1	10	200	330	65
TPK30KP51A	TPK30KP51CA	51	56.7-62.7	5	82.4	10	200	366	58
TPK30KP54	TPK30KP54C	54	60.0-73.3	5	96.3	10	200	312	68
TPK30KP54A	TPK30KP54CA	54	60.0-66.3	5	87.1	10	200	342	64
TPK30KP58	TPK30KP58C	58	64.4-78.7	5	103.0	10	200	294	75
TPK30KP58A	TPK30KP58CA	58	64.4-71.2	5	93.6	10	200	318	70
TPK30KP60	TPK30KP60C	60	66.7-81.5	5	107.0	10	200	282	80
TPK30KP60A	TPK30KP60CA	60	66.7-73.7	5	96.8	10	200	312	72
TPK30KP64	TPK30KP64C	64	71.1-86.9	5	114.0	10	200	264	85
TPK30KP64A	TPK30KP64CA	64	71.1-78.6	5	103.0	10	200	294	75

Technical Data
Data Sheet N0051, Rev. I



Part Number (Unidirectional)	Part Number (Bidirectional)	Stand-off Voltage V_{WM} (Note 1) (V)	Breakdown Voltage V_{BR} @ I_{BR} (mA) (V)		Clamping Voltage V_C (10*1000) @ I_{PP} (V) Max	Stand By Current I_R @ V_{WM} (μ A) Max	Stand By Current I_R @ V_{WM} $T_J=150^\circ C$ (μ A) Max	Peak Pulse Current I_{PP} Max	Temperatur e Coefficient Of V_{BR} $mV/^\circ C$ Max
TPK30KP70	TPK30KP70C	70	77.8-95.1	5	125	10	200	240	93
TPK30KP70A	TPK30KP70CA	70	77.8-86.0	5	113	10	200	264	84
TPK30KP75	TPK30KP75C	75	83.3-102.0	5	134	10	200	222	100
TPK30KP75A	TPK30KP75CA	75	83.3-92.1	5	121	10	200	246	90
TPK30KP78	TPK30KP78C	78	86.7-106.0	5	139	10	200	216	104
TPK30KP78A	TPK30KP78CA	78	86.7-95.8	5	126	10	200	240	95
TPK30KP85	TPK30KP85C	85	94.4-115.0	5	151	10	200	198	115
TPK30KP85A	TPK30KP85CA	85	94.4-104.0	5	137	10	200	216	104
TPK30KP90	TPK30KP90C	90	100-122	5	160	10	200	186	120
TPK30KP90A	TPK30KP90CA	90	100-111	5	146	10	200	204	109
TPK30KP100	TPK30KP100C	100	111-136	5	179	10	200	168	134
TPK30KP100A	TPK30KP100CA	100	111-123	5	162	10	200	186	122
TPK30KP110	TPK30KP110C	110	122-149	5	196	10	200	156	147
TPK30KP110A	TPK30KP110CA	110	122-135	5	177	10	200	168	132
TPK30KP120	TPK30KP120C	120	133-163	5	214	10	200	140	161
TPK30KP120A	TPK30KP120CA	120	133-147	5	193	10	200	156	145
TPK30KP130	TPK30KP130C	130	144-176	5	231	10	200	130	174
TPK30KP130A	TPK30KP130CA	130	144-159	5	209	10	200	142	157
TPK30KP150	TPK30KP150C	150	167-204	5	268	10	200	112	202
TPK30KP150A	TPK30KP150CA	150	167-185	5	243	10	200	124	183
TPK30KP160	TPK30KP160C	160	178-218	5	287	10	200	104	216
TPK30KP160A	TPK30KP160CA	160	178-197	5	259	10	200	116	195
TPK30KP170	TPK30KP170C	170	189-231	5	304	10	200	98	229
TPK30KP170A	TPK30KP170CA	170	189-209	5	275	10	200	110	207
TPK30KP180	TPK30KP180C	180	200-244	5	321	10	200	94	242
TPK30KP180A	TPK30KP180CA	180	200-221	5	291	10	200	104	219
TPK30KP200	TPK30KP200C	200	222-271	5	356	10	200	84	269
TPK30KP200A	TPK30KP200CA	200	222-245	5	322	10	200	94	243
TPK30KP220A	TPK30KP220CA	220	245-271	5	356	10	200	84	269
TPK30KP260A	TPK30KP260CA	260	289-320	5	419	10	200	71	318
TPK30KP280A	TPK30KP280CA	280	311-345	5	451	10	200	66	344
TPK30KP300A	TPK30KP300CA	300	333-369	5	483	10	200	62	368
TPK30KP350A	TPK30KP350CA	350	389-431	5	564	10	200	53	430
TPK30KP400A	TPK30KP400CA	400	444-492	5	644	10	200	46	490

NOTE 1: Transient Voltage Suppressors are normally selected with reverse "Stand Off Voltage" V_{WM} which should be equal to or greater than the dc or continuous peak operating voltage level.

2: TPK30KPXXA, "A" Suffix Designates Unidirectional Devices; TPK30KPXXCA, "CA" Suffix Designates Bidirectional Devices.

SYMBOLS & DEFINITIONS			
Symbol	Definition	Symbol	Definition
V_{WM}	Working Peak(Standoff) Voltage	I_{PP}	Peak Pulse Current
$V_{(BR)}$	Breakdown Voltage	V_C	Claming Voltage
I_R	Standby Current	$I_{(BR)}$	Breakdown Current for $V_{(BR)}$

Ratings and Characteristics Curves

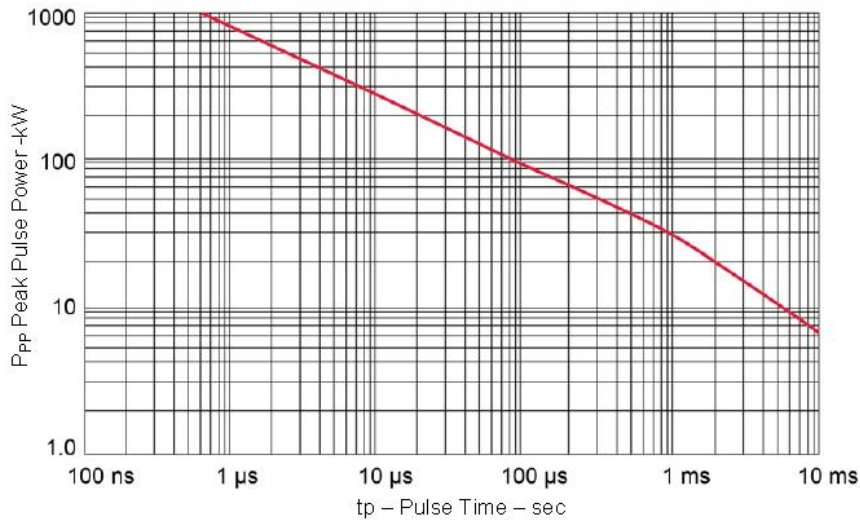

FIGURE 1
Peak Pulse Power vs. F

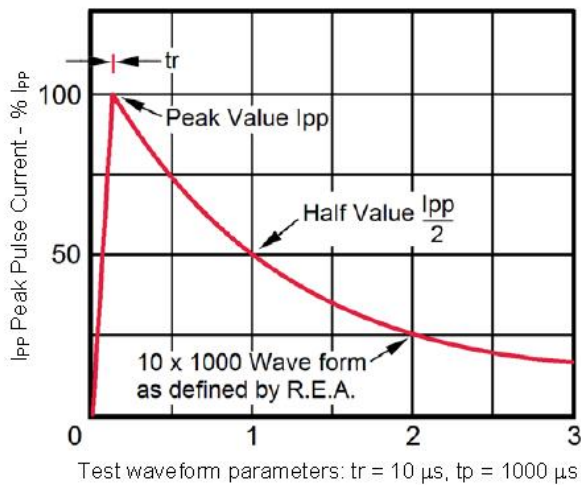

Figure 2
Pulse Waveform

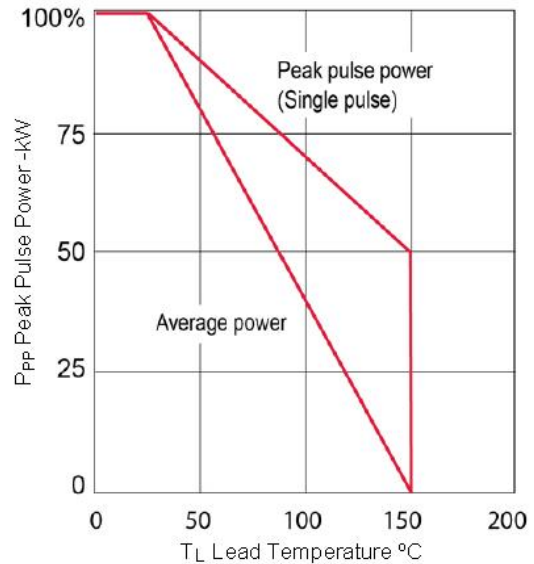
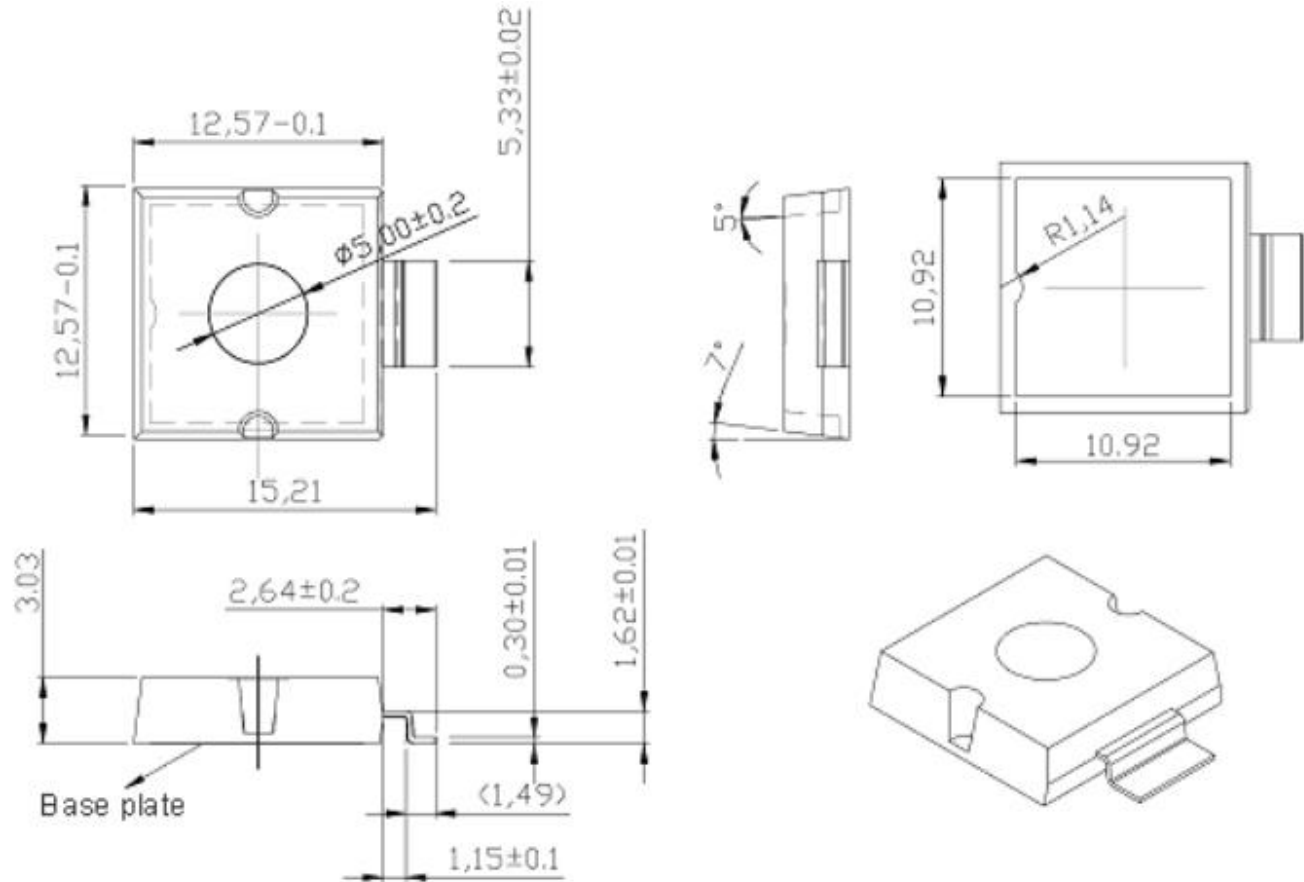

FIGURE 3
Derating Curve

Mechanical Dimensions SPD-4(Millimeters)



Ordering Information

Device	Package	Shipping
TPK30KPXX	SPD-4 (Pb-Free)	64pcs/bag
TPK30KPXXTR	SPD-4 (Pb-Free)	500pcs/reel

For information on tape and reel specifications, including part orientation and tape sizes, please refer to our tape and reel packaging specification.

Marking Diagram

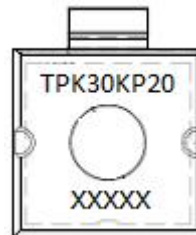

Where XXXXX is YYWWL
Part number's example like this

TPK30KP20 = Part Number
YY = Year
WW = Week
L = Lot Number

Notes : Reliability Level will Marking.

Date code "XXXXX" was added in marking from April 1, 2019.

PAD Layout Recommend Size(Millimeters)

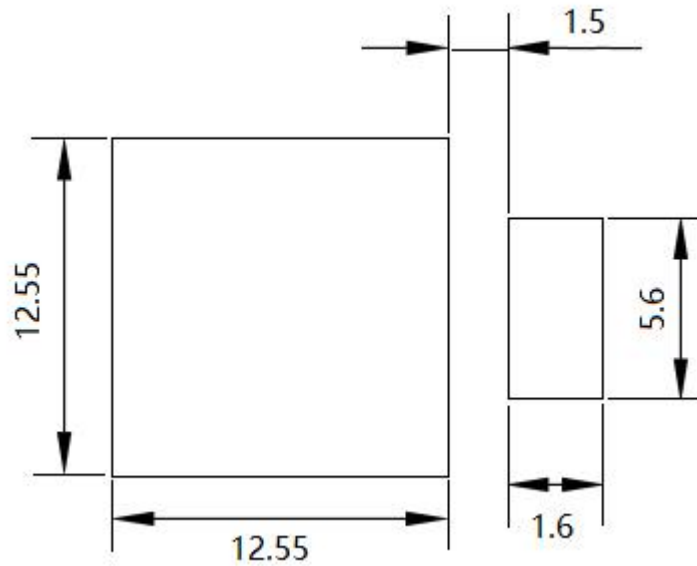

Part Number Naming Rule

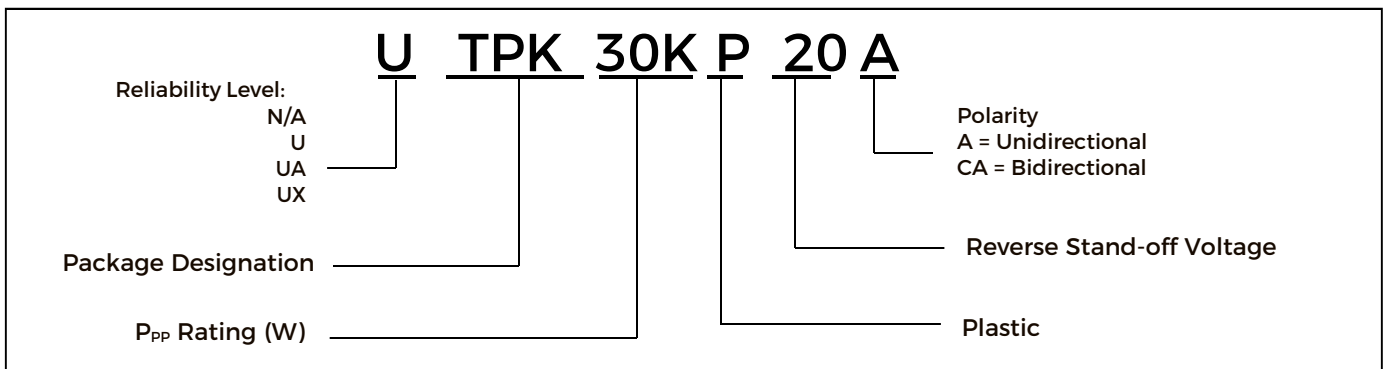



SMC TVS Screening Options					
Screen or Test Description	Screening Options				
	Prefix	1)	U	UA	UX
100% Wafer Probe		R	R	R	R
3-Sigma lot norm determination 2)			R	R	R
Surge Test		1x	1x	1x	1x
100% DC Electrical Test Go-No-Go			R	R	R
Temperature Cycling			10 Cycles 3)	10 Cycles	20 Cycles
Post TC Surge Test			1x 3)	3x	10x
100% Thermal Impedance 4)			R	R	R
100% DC Electrical Test				go-no-go	R
HTRB				24 hrs 5)	96 hrs 6)
100% DC Electrical Test		go-no-go	go-no-go	go-no-go	R
Delta Calculation					R
PDA Calculation					R
100% Visual Inspection		R	R	R	R
Certificate of Conformance		R	R	R	R
Group A Inspection					O
Group B Inspection					O
Group C Inspection					O

Notes:

R = to be performed. Electrical testing per datasheet limits
O = optional

1) Commercial flow

2) 3-Sigma lot norm to remove atypical devices. For detailed requirements see below.

3) Test to be performed on TPK & STPK Series only. The condition is below:

High temp. side: 150 °C; Low temp. side: -55 °C; Duration time: HT 15min, LT 15 min

4) To be performed any time before completion of screening for unidirectional devices only.

5) 24 hours for unidirectional, 24 hours each side for bidirectional

6) 96 hours for unidirectional, 48 hours each side for bidirectional

Test Procedure to remove Atypical Devices

This procedure will be used in the production testing and applied for each assembly lot when required by the screening option.

- read and record VBR and IR of 200 random samples of a particular assembly lot.
- calculate the average (μ) and standard deviation (σ) for each parameter.
- the testing limit will then be as follows:
 - $VBR\ min = \mu(VBR) - 3\sigma(VBR)$
 - $VBR\ max = \mu(VBR) + 3\sigma(VBR)$
 - $IR\ max = \mu(IR) + 3\sigma(IR)$

Once the testing limit is established for this assembly lot, the 100% production testing will be done based on the tighter limit for the parts of the same assembly lot.

**DISCLAIMER:**

- 1- The information given herein, including the specifications and dimensions, is subject to change without prior notice to improve product characteristics. Before ordering, purchasers are advised to contact the SMC Diode Solutions sales department for the latest version of the datasheet(s).
- 2- In cases where extremely high reliability is required (such as use in nuclear power control, aerospace and aviation, traffic equipment, medical equipment, and safety equipment), safety should be ensured by using semiconductor devices that feature assured safety or by means of users' fail-safe precautions or other arrangement.
- 3- In no event shall SMC Diode Solutions be liable for any damages that may result from an accident or any other cause during operation of the user's units according to the datasheet(s). SMC Diode Solution assumes no responsibility for any intellectual property claims or any other problems that may result from applications of information, products or circuits described in the datasheets.
- 4- In no event shall SMC Diode Solutions be liable for any failure in a semiconductor device or any secondary damage resulting from use at a value exceeding the absolute maximum rating.
- 5- No license is granted by the datasheet(s) under any patents or other rights of any third party or SMC Diode Solutions.
- 6- The datasheet(s) may not be reproduced or duplicated, in any form, in whole or part, without the expressed written permission of SMC Diode Solutions.
- 7- The products (technologies) described in the datasheet(s) are not to be provided to any party whose purpose in their application will hinder maintenance of international peace and safety nor are they to be applied to that purpose by their direct purchasers or any third party. When exporting these products (technologies), the necessary procedures are to be taken in accordance with related laws and regulations..